

HAGLUND INDUSTRI

BLAST CHILLER FREEZER 2024



HAGLUND INDUSTRI
KYLA I ALLA FORMER

150 YEARS OF INNOVATION CAN BE SEEN IN THE DETAILS

For five generations, the Haglund family has had its own production at the factory in Sweden. From the early sheet metal workshop to today's high-quality refrigerators, the basic recipe has remained the same: listen to customers, pay attention to details and never stop developing technology and functionality. This tradition is what's built into all our products, giving them a finish and durability that makes us slightly unique. The products are also thoroughly tested, first by us and then by our customers. Try for yourself and notice the difference.

FEEL FREE TO CONTACT US FOR A ESTIMATE

Every restaurant and hospitality establishment has its own needs and specific requirements. We are happy to help you find a solution that suits your needs the best. Call or email us and tell us what you need and we will give you a proposal and ON REQUEST.

EMAIL US: SALES@HAGLUNDINDUSTRI.SE

OR CALL: +46 (0) 321-29 990

3 BLAST CHILLER / FREEZER

5 BRIS 600 QUICK CHILLER CABINET

6 BRIS 600 QUICK CHILLER CABINET TOUCH PANEL

7 BRIS 850 QUICK CHILLER CABINET

8 BRIS 850 QUICK CHILLER CABINET TOUCH PANEL

9 STORM MINI

14 BRIS 850 BLAST CHILLER CABINET

17 STORM 960 BLAST CHILLER/FREEZER CABINET

18 STORM 1200 BLAST CHILLER ROOM

19 STORM 1500 BLAST CHILLER/FREEZER ROOM

20 STORM 1800 BLAST CHILLER/FREEZER ROOM



**HAGLUND
INDUSTRI**
KYLA I ALLA FORMER

BLAST CHILLER

**BLAST CHILLER COUNTER / BLAST CHILLER CABINET BRIS 850 & STORM 960
/ BLAST CHILLER ROOM STORM 1200, 1500 & 1800 / BLAST-CHILLER CABINET**

A **BLAST CHILLER** REDUCES FOOD TEMPERATURES FROM +70° TO +3° WITHIN 90 MINUTES. BACTERIA GROWS BEST IN FOODS BETWEEN +10° TO +70°. TO MAINTAIN ORIGINAL FOOD QUALITY, HAGLUND'S BLAST CHILLER CABINET SUITS EVERY CHEF'S DESIRE FOR OPTIMAL FOOD PRESERVATION.

DIRECT COOLING WE USE A TECHNIQUE WE CALL DIRECT COOLING, WHICH MEANS WE BLAST THE FOOD-FILLED GASTRONORM CONTAINERS DIRECTLY WITH THE COLDEST AIR. THIS ENSURES THAT VIRTUALLY ALL THE COLD AIR HITS THE HOT FOOD DIRECTLY AND GUARANTEES THE BEST EFFICIENCY.

STORM 960 BLAST CHILLER: HOT TO COLD IN NO TIME



ENERGY-EFFICIENT CHILLING

STORM 960 / 1200 / 1500 / 1800

The easy-to-use control system in combination with Direct Cooling technology ensures efficient chilling.

HIGH AIRFLOW

STORM 960 / 1200 / 1500 / 1800

Our advanced system directs the airflow towards the food for optimal cooling.

ROUNDED INTERIOR CORNERS

STORM 960

For easy cleaning, the cabinet is equipped with rounded interior corners.

EFFICIENT FAN

STORM 960 / 1200 / 1500 / 1800

The powerful fan is capable of transporting large amounts of air and delivers chilling that is just as efficient as it is gentle. The fan is one of the reasons why the chilling is so efficient.

ADAPTED FOR MOBILE OVEN RACKS

STORM 960 / 1200 / 1500 / 1800

Delivered adapted for the following mobile oven racks: Rational iCombi PRO/Classic 20-1/1, Hounö 1.16 or Hounö 1.20, that can be wheeled into the cabinet. The door can be closed with the trolley inside the cabinet. Also suitable for Rational SCC201.

INSULATED FLOOR

STORM 960

Energy-efficient solution that also facilitates cleaning under the cabinet. By separating the inner part from the wheels of the trolley the cabinet is more hygienic as floor dirt does not accompany the wheels inside.

DRAIN

STORM 960

The drain is located under the cabinet and connected to the well.



4 REASONS TO CHOOSE A BLAST CHILLER

1. ENERGY-EFFICIENT COOLING SYSTEM

With an expansion valve as standard, Propane (R-290) as a refrigerant, and cooling air taken to the condenser from the floor, BRIS provides high efficiency with low energy consumption in all climate conditions. The technology also allows for placement against the wall as the back is ventilated.

2. STAINLESS STEEL GRID SHELVES

5 stainless steel grid shelves mounted on removable stainless steel guides that are stylish, practical and durable are supplied as standard.

3. EXTRA VOLUME

Space is often limited in a kitchen, but with our cabinets you make the most of the interior volume. The design provides maximum space for refrigerated products.

4. HEAVY-DUTY HANDLES

The door has a strong stainless steel handle and is self-closing and equipped with magnetic strips which are easy to clean and can be replaced easily by hand. Locks are fitted as standard.

BRIS 600
CHILLER
TOUCH PANEL



BRIS 850
CHILLER
TOUCH PANEL

BRIS 600
CHILLER



BRIS 850
CHILLER

STORM MINI



15KG

BRIS 850
BLAST
CHILLER



25KG
36KG
45KG

BRIS 600 QUICK CHILLER CABINET

QUICK CHILLER 35KG

BUILT-IN UNIT

MODEL	TYPE	DIM (mm)
BRIS-600NA	QUICK CHILLER	600x765x2160
BRIS-600NKA	QUICK CHILLER/REFRIGERATOR	600x765x2160
BRIS-600NFA	QUICK CHILLER/FREEZER	600x765x2160 **

REMOTE COOLING UNIT

MODEL	TYPE	DIM (mm)
BRIS-600NC	QUICK CHILLER	600x765x2160
BRIS-600NKC	QUICK CHILLER/REFRIGERATOR	600x765x2160
BRIS-600NFC	QUICK CHILLER/FREEZER	600x765x2160

STANDARD: MADE OF ENTIRELY STAINLESS STEEL / LOCK / REMOVABLE EVAPORATOR TRAY IN STAINLESS STEEL / LOW-ENERGY FAN / 5 STAINLESS STEEL GRID SHELVES / HYGIENE TOP COVER (REMOTE COOLING UNIT) / TIMER CONTROLLED COOLING UNIT

CAPACITY: 35 KG

CAPACITY REFERS TO CHILLING FROM +60°C TO +8°C IN 4 HOURS

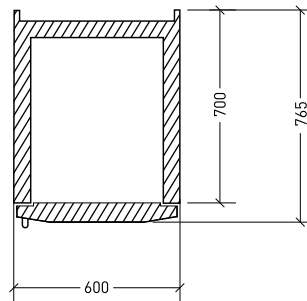

BRIS 600NA CHILLER



ENERGY-EFFICIENT

The cooling system has an expansion valve as standard, which provides accurate temperature control and adapts the compressor's performance to the current ambient temperature.

BRIS 600NKC CHILLER COMBI



**ADJUSTABLE
LEGS**
130-180 mm

TECHNICAL DATA

BUILT-IN UNIT

MODEL	POWER SUPPLY	CONNECTED POWER	CHILLING CAPACITY	REFRIGERANT
BRIS-600NA	230V/10A	1050 W	35 KG (4h)	R-290
BRIS-600NKA	230V/10A	1050 W	15 KG (4h)	R-290
BRIS-600NFA	230V/10A	1080 W	15 KG (4h)	R-290

REMOTE COOLING UNIT

MODEL	POWER SUPPLY	CONNECTED POWER	CHILLING CAPACITY	COOLING REQUIREMENT (W)	REFRIGERANT
BRIS-600NC	230V/10A	550 W	35 KG (4h)	1200 / -10°C	R-452A*
BRIS-600NKC	230V/10A	680 W	15 KG (4h)	900 / -10°C + 200 / -8°C	R-134a/R-452A*
BRIS-600NFC	230V/10A	680 W	15 KG (4h)	900 / -10°C + 200 / -28°C	R-134a/R-452A*

*CO2 or other refrigerant can be supplied upon request.

BRIS 600 QUICK CHILLER CABINET TOUCH PANEL

QUICK CHILLER 35KG

BUILT-IN UNIT

MODEL	TYPE	DIM (mm)
BRIS-600S1A	QUICK CHILLER	600x765x2160

REMOTE COOLING UNIT

MODEL	TYPE	DIM (mm)
BRIS-600S1C	QUICK CHILLER	600x765x2160

STANDARD: MADE OF ENTIRELY STAINLESS STEEL / LOCK / REMOVABLE EVAPORATOR TRAY IN STAINLESS STEEL / LOW-ENERGY FAN / 5 STAINLESS STEEL GRID SHELVES / HYGIENE TOP COVER (REMOTE COOLING UNIT) / INSERT SENSOR

CAPACITY: 35 KG

CAPACITY REFERS TO CHILLING FROM +60°C TO +8°C IN 4 HOURS

Cabinets with Remote Cooling Unit supplied as standard with valve for R-452A.

EXTRA EQUIPMENT

CAREL SERIAL CONNECTION MODULE

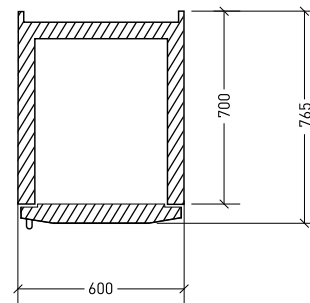

BRIS 600
CHILLER
TOUCH
PANEL



START WITH A TOUCH

The cabinets are delivered with a graphic touch panel controller in colour that saves the history for up to one year.

ADJUSTABLE
LEGS
130-180 mm

TECHNICAL DATA

BUILT-IN UNIT

MODEL	POWER SUPPLY	CONNECTED POWER	CHILLING CAPACITY	REFRIGERANT
BRIS-600S1A	230VAC / 10A	1200 W	35 KG (4h)	R-290

REMOTE COOLING UNIT

MODEL	POWER SUPPLY	CONNECTED POWER	CHILLING CAPACITY	COOLING REQUIREMENT (W)	REFRIGERANT
BRIS-600S1C	230VAC / 10A	750 W	35 KG (4h)	1200 / -10°C	R-134a/R-452A*

*CO2 or other refrigerant can be supplied upon request.

BRIS 850 QUICK CHILLER CABINET

QUICK CHILLER 50 KG

BUILT-IN UNIT

MODEL	TYPE	DIM (mm)
BRIS-850NA	QUICK CHILLER	850x765x2160
BRIS-850NKA	QUICK CHILLER/REFRIGERATOR	850x765x2160
BRIS-850NFA	QUICK CHILLER/FREEZER	850x765x2160 **

REMOTE COOLING UNIT

MODEL	TYPE	DIM (mm)
BRIS-850NC	QUICK CHILLER	850x765x2160
BRIS-850NKC	QUICK CHILLER/REFRIGERATOR	850x765x2160
BRIS-850NFC	QUICK CHILLER/FREEZER	850x765x2160

STANDARD: MADE OF ENTIRELY STAINLESS STEEL / LOCK / REMOVABLE EVAPORATOR TRAY IN STAINLESS STEEL / LOW-ENERGY FAN / 5 STAINLESS STEEL GRID SHELVES / HYGIENE TOP COVER (REMOTE COOLING UNIT) / TIMER CONTROLLED COOLING UNIT

CAPACITY: 50 KG

CAPACITY REFERS TO CHILLING FROM +60°C TO +8°C IN 4 HOURS

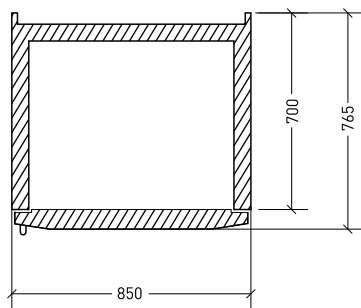

BRIS 850
QUICK CHILLER



ADJUSTABLE
LEGS
130-180 mm

BRIS 850
QUICK CHILLER
COMBI



ADJUSTABLE
LEGS
130-180 mm

TECHNICAL DATA

BUILT-IN UNIT

MODEL	POWER SUPPLY	CONNECTED POWER	CHILLING CAPACITY	REFRIGERANT
BRIS-850NA	230VAC / 10A	1200 W	50 KG (4h)	R-290
BRIS-850NKA	230VAC / 10A	1050 W **	25 KG (4h)	R-290
BRIS-850NFA	230VAC / 10A	1050 W **	25 KG (4h)	R-290

REMOTE COOLING UNIT

MODEL	POWER SUPPLY	CONNECTED POWER	CHILLING CAPACITY	COOLING REQUIREMENT (W)	REFRIGERANT
BRIS-850NC	230VAC / 10A	750 W	50 KG (4h)	1700/-10°C	R-134a/R-452A*
BRIS-850NKC	230VAC / 10A	875 W **	25 KG (4h)	1100/-10°C + 200/-8°C	R-134a/R-452A*
BRIS-850NFC	230VAC / 10A	875 W **	25 KG (4h)	1100/-10°C + 250/-28°C	R-134a/R-452A*

*CO2 or other refrigerant can be supplied upon request.

**Can be delivered with double separate plugs

BRIS 850 QUICK CHILLER CABINET TOUCH PANEL

QUICK CHILLER 50 KG

BUILT-IN UNIT

MODEL	DIM (mm)
BRIS-850S1A	850x765x2160

REMOTE COOLING UNIT

MODEL	DIM (mm)
BRIS-850S1C	850x765x2160

STANDARD: MADE OF ENTIRELY STAINLESS STEEL / LOCK / REMOVABLE EVAPORATOR TRAY IN STAINLESS STEEL / LOW-ENERGY FAN / 5 STAINLESS STEEL GRID SHELVES / HYGIENE TOP COVER (REMOTE COOLING UNIT) / INSERT SENSOR

CAPACITY: 50 KG

CAPACITY REFERS TO CHILLING FROM +60°C TO +8°C IN 4 HOURS

Cabinets with Remote Cooling Unit supplied as standard with valve for R-452A.

EXTRA EQUIPMENT

CAREL SERIEANSLUTNINGSMODUL

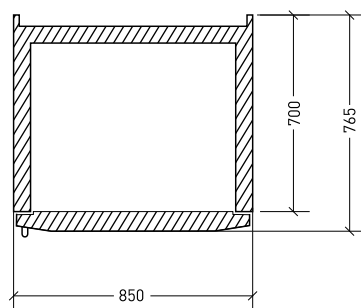

BRIS 850
QUICK CHILLER
TOUCH PANEL



ADJUSTABLE
LEGS
130-180 mm

START WITH A TOUCH

The cabinets are delivered with a graphic touch panel controller in colour that saves the history for up to one year.

TECHNICAL DATA

BUILT-IN UNIT

MODEL	POWER SUPPLY	CONNECTED POWER	CHILLING CAPACITY	REFRIGERANT
BRIS-850S1A	230VAC / 10A	1200 W	50KG (4h)	R-290

REMOTE COOLING UNIT

MODEL	POWER SUPPLY	CONNECTED POWER	CHILLING CAPACITY	COOLING REQUIREMENT (W)	REFRIGERANT
BRIS-850S1C	230VAC / 10A	750 W	50KG (4h)	1700 / -10°C	R-134a/R-452A*

*CO2 or other refrigerant can be supplied upon request.

STORM

STORM MINI / STORM 960 / STORM 1200 / STORM 1500 / STORM 1800

STORM MINI IS AN INCREDIBLY PRACTICAL AND EFFICIENT SMALL CABINET THAT CAN BE PLACED UNDER A COUNTER OR AN OVEN.

SEE PRODUCT SHEET ON PAGE 13



STORM MINI DIRECT COOLING™ – OUR OWN ENERGY-EFFICIENT TECHNOLOGY

Innovative technical solution for fast and controlled chilling. Unique design that chills with large volumes of air and provides more uniform and efficient chilling.

STORM MINI BLAST CHILLING IN A COMPACT DESIGN

Smart and effective use of the kitchen space are important factors for our customers. With the new STORM MINI, the often unused space under the oven is put to good use.



EFFICIENT



4 REASONS TO CHOOSE STORM

1. DIRECT COOLING

Our proprietary direct cooling system is guaranteed to give you the best possible results in a very energy-effective manner.

2. GENTLE CHILLING

It's not only important to cool food down quickly, it's also important to do it gently. The even temperature and high airflow, combined with programs designed for different dishes, ensures high quality of the chilled food while quickly bringing it down to a safe temperature.

3. ENERGY-EFFICIENT CHILLING

Our cooling method using large airflows instead of unnecessarily cold air, combined with our advanced control equipment minimises energy consumption.

4. EASY-TO-USE

Our proprietary touch panel with a intuitive user interface makes it easy for kitchen staff to get started and monitor the chilling process. It is also possible to save the history to a USB stick.



EASY TO CONTROL WITH A TOUCH PANEL

User-friendly exterior with technologically advanced interior. The touch panel gives you easy access to a wealth of functions.

INTEGRATED DATA LOGGING

Save the last 100 chilling cycles and browse the history with the touch panel. Save the information on a USB stick for HACCP control.

CREATE CUSTOM PROGRAMS

Add to the standard programs and customise your STORM to your needs with up to 10 custom cooling programs.

FROM THE MINI TO COMPLETE BLAST CHILLER ROOMS – STORM HAS A SOLUTION FOR EVERY NEED.



BLAST CHILLING WITH THE HIGHEST QUALITY AND 30% LOWER ENERGY CONSUMPTION.

STORM PROCESS

CHILLING / PROOFING / THAWING

OUR NEWLY DEVELOPED CONTROL UNIT TAKES SIMPLICITY TO A NEW LEVEL, YOU NO LONGER NEED TO UNDERSTAND THE TECHNOLOGY TO ACHIEVE EFFICIENT AND SAFE CHILLING, STORM PROCESS DOES IT FOR YOU.



MULTIFUNCTION

Chilling, proofing or thawing, you're more flexible with STORM process.

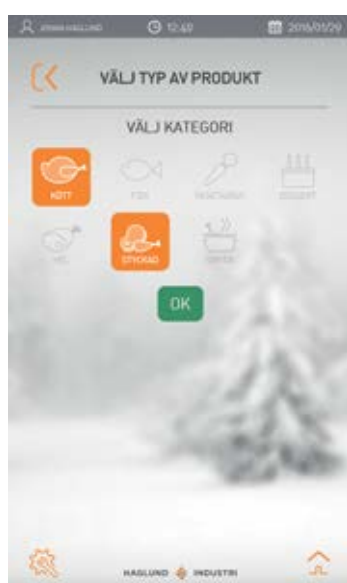

EASY TO START

If you know what you want to chill, STORM Process does the rest.

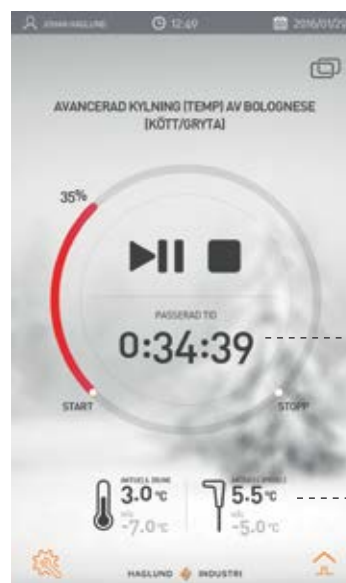

Indication of time remaining

Clear indication of current temperature and target temperature

OPERATION DISPLAY

The operation display only displays the most important information.

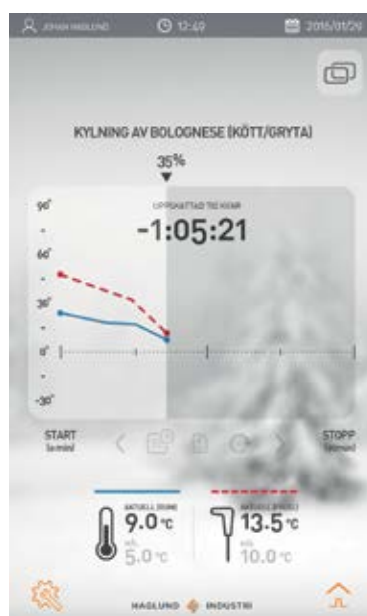
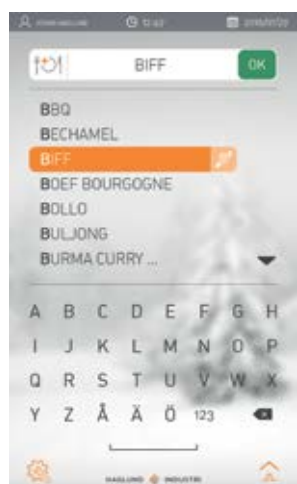
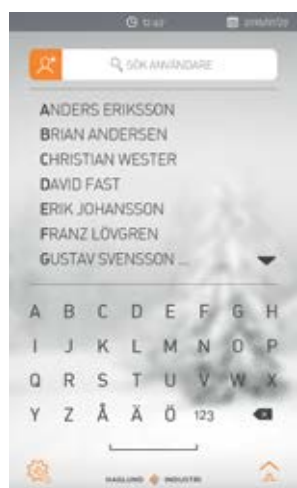

INFORMATION FOR EACH CHILLED DISH CAN BE SAVED ON A USB STICK (PDF).

GRAPHIC LOGGING (OPTIONAL)

Each chilling cycle is logged with the name of the user and the product, total cooling time and a visual curve. The chilling is HACCP-safe and your records keeping will be made very simple.



HAGLUND'S BLAST CHILLING TECHNOLOGY

DIRECT COOLING™

HAGLUND HAS BEEN DEVELOPING BLAST CHILLING TECHNOLOGY FOR MANY YEARS. A UNIQUE TECHNOLOGY WITH INGENUOUS AIRFLOW CONTROL COMBINED WITH VERY POWERFUL COOLING UNIT AND INTENSE AIRFLOW THAT CLEVERLY PRESERVE THE FOOD'S PROPERTIES, WHILE CHILLING EXTREMELY EVENLY AND ENERGY-EFFICIENTLY.

HAGLUND STORM DIRECT COOLING

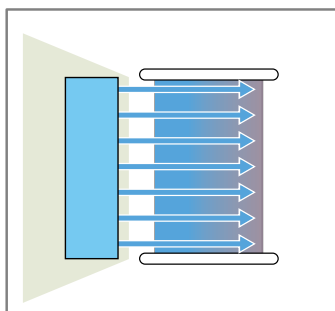

VIEW FROM ABOVE

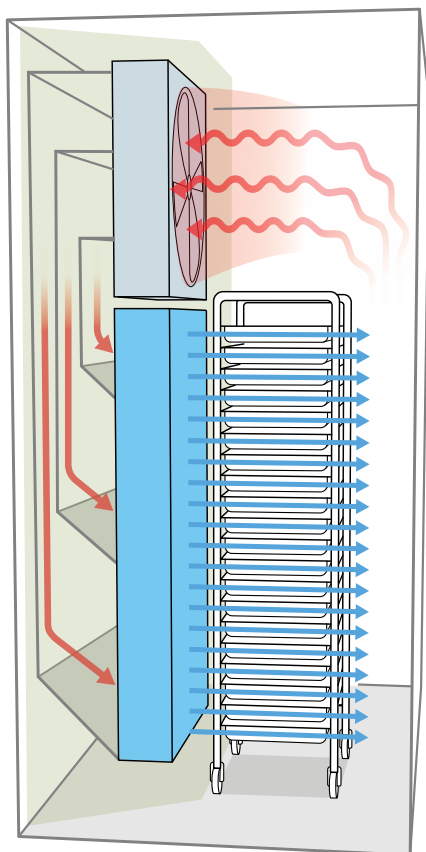

VIEW FROM THE SIDE

ADVANTAGES:

- No edge freezing
- Even cooling
- Chilled food of high quality
- Fast chilling
- Energy-efficient chilling
- You can rely on the stated capacity

TRADITIONAL BLAST CHILLER INDIRECT COOLING

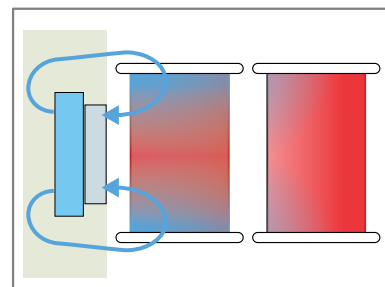

VIEW FROM ABOVE

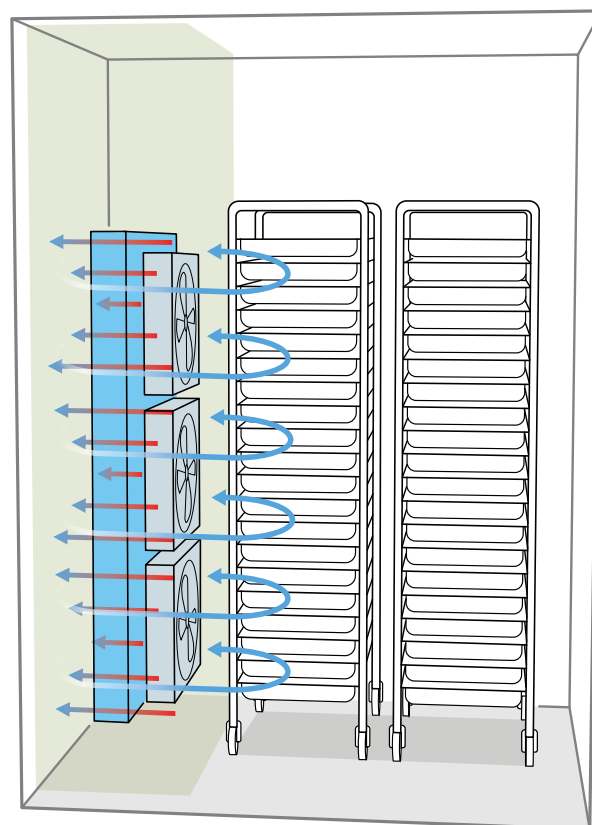

VIEW FROM THE SIDE

COMMON PROBLEMS:

- Uneven cooling
- Products are dried out
- Slow chilling
- Edge freezing
- High energy consumption

STORM MINI

BLAST CHILLER 15 -25 KG

FOR PLACEMENT UNDER A COUNTER

MODEL	DIMENSIONS	CAPACITY	NUMBER GN1/1
STORM-5A	850x700x900*	15 KG	4/6**
STORM-5C	850x700x900*	15 KG	4/6**

FOR PLACEMENT UNDER RATIONAL 61

MODEL	DIMENSIONS	CAPACITY	NUMBER GN1/1
STORM-5A-01	850x750x840	15 KG	4/6**
STORM-5C-01	850x750x840	15 KG	4/6**

CAPACITY: 15 KG

CAPACITY REFERS TO CHILLING FROM +70°C TO +3°C IN 90 MINUTES

CAPACITY: 45 KG

CAPACITY REFERS TO CHILLING FROM +60°C TO +8°C IN 240 MINUTES

Cabinets with remote cooling unit cabinets can be supplied for all refrigerants available on the market, either with a thermal expansion valve or an with an electronic expansion valve. Includes valve for R-452A.

EXTRA EQUIPMENT

WHEELS INCLUDING 2 LOCKABLE

BLAST FREEZER FUNCTION

WATER-COOLED COMPRESSOR

CAREL SERIAL CONNECTION MODULE

LIGHTING

*incl countertop

**4st GN1/1-65 alt. 6st GN1/1-40

Available in 2 different heights for placement at counter height or under the oven. Can be delivered without a countertop.

STORM
MINI



DIRECT COOLING

The blast chiller counter is a standard product adapted for GN1/1. These cabinets are equipped with our Direct Cooling technology developed for the STORM series.

30%

Lower energy consumption

NEW!

Now with the eco-friendly R-290 refrigerant!

TECHNICAL DATA

BUILT-IN UNIT

MODEL	POWER SUPPLY	CONNECTED POWER	REFRIGERANT
STORM-5A	230V/10A	1 400 W	R-290*

REMOTE COOLING UNIT

MODEL	POWER SUPPLY	CONNECTED POWER	COOLING REQUIREMENT (W)	BLAST FREEZER FUNCTION	REFRIGERANT
STORM-5C	230V/10A	600 W	1800/-15°C	2500/-30°C	R-452A*

*CO2 or other refrigerant can be supplied upon request.

Please note! COOLING REQUIREMENT: A rated requirement. Please note that the evaporator temperature have a need to go lower to reach full capacity, please ask us for consultation.

BRIS 850 BLAST CHILLER CABINET

BLAST CHILLER 25 - 40 KG

BUILT-IN UNIT

MODEL	DIMENSIONS (mm)
BRIS-850S2A	850x765x2160

REMOTE COOLING UNIT

MODEL	DIMENSIONS (mm)
BRIS-850S2C	850x765x2160

STANDARD: MADE OF ENTIRELY STAINLESS STEEL / 12 RAIL PAIRS FOR GN1/1 / POWERFUL EVAPORATOR FAN / ADVANCED AIR DISTRIBUTION SYSTEM / LOCK / FOOD PROBE / GRAPHIC 5.7" TOUCH PANEL CONTROL UNIT IN COLOUR

CAPACITY: 25 KG

CAPACITY REFERS TO CHILLING FROM +70°C TO +3°C IN 90 MINUTES

CAPACITY: 75 KG

CAPACITY REFERS TO CHILLING FROM +60°C TO +8°C IN 240 MINUTES

Cabinets with remote cooling unit can be supplied for all refrigerants available on the market, either with a thermal expansion valve or an electronic expansion valve. The includes valve for R-452A (freezer) or R-134a (refrigerator).

EXTRA EQUIPMENT

- LIGHTING
- FOOT PEDAL
- BUILT-IN DATA LOGGING WITH USB PORT
- WHEELS INCLUDING 2 LOCKABLE
- BLAST FREEZER FUNCTION
- WATER-COOLED CONDENSER
- HEIGHT=1950 (REMOTE COOLING UNIT)
- CAREL SERIAL CONNECTION MODULE

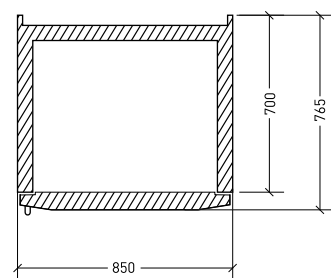

30%
Lower energy consumption

NEW!
Now with the eco-friendly R-290 refrigerant!

ADJUSTABLE LEGS
130-180 mm

DIRECT COOLING
The blast chiller cabinet is a standard product adapted for GN1/1. These cabinets are equipped with our Direct Cooling technology developed for the STORM series.

TECHNICAL DATA

BUILT-IN UNIT

MODEL	POWER SUPPLY	CONNECTED POWER	CHILLING CAPACITY	REFRIGERANT
BRIS-850S2A	230 VAC / 13A	2 250 W	25 KG	R-452A

REMOTE COOLING UNIT

MODEL	POWER SUPPLY	CONNECTED POWER	CHILLING CAPACITY	COOLING REQUIREMENT (W)	REFRIGERANT
BRIS-850S2C	230 VAC / 10A	1 650 W	25 KG	2000 / -15°C	R-452A*

*CO2 or other refrigerant can be supplied upon request.

Please note! COOLING REQUIREMENT: A rated requirement. Please note that the evaporator temperature have a need to go lower to reach full capacity, please ask us for consultation.

BRIS 850 BLAST CHILLER CABINET

BLAST CHILLER 36 - 60 KG

BUILT-IN UNIT

MODEL	DIMENSIONS (mm)
BRIS-850S3A	850x765x2160

REMOTE COOLING UNIT

MODEL	DIMENSIONS (mm)
BRIS-850S3C	850x765x2160

STANDARD: MADE OF ENTIRELY STAINLESS STEEL / 12 RAIL PAIRS FOR GN1/1 / POWERFUL EVAPORATOR FAN / ADVANCED AIR DISTRIBUTION SYSTEM / GRAPHIC 5.7" TOUCH PANEL CONTROL UNIT IN COLOUR / LOCK / FOOD PROBE

CAPACITY: 36 KG

CAPACITY REFERS TO CHILLING FROM +70°C TO +3°C IN 90 MINUTES

CAPACITY: 100 KG

CAPACITY REFERS TO CHILLING FROM +60°C TO +8°C IN 240 MINUTES

Cabinets with remote cooling unit can be supplied for all refrigerants available on the market, either with a thermal expansion valve or an electronic expansion valve. The includes valve for R-452A (freezer) or R-134a (refrigerator).

EXTRA EQUIPMENT

LIGHTING
FOOT PEDAL
BUILT-IN DATA LOGGING WITH USB PORT
WHEELS INCLUDING 2 LOCKABLE
BLAST FREEZER FUNCTION
WATER-COOLED CONDENSER
HEIGHT=1950 (REMOTE COOLING UNIT)
CAREL SERIAL CONNECTION MODULE

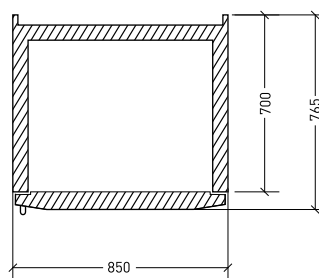

BRIS 850
BLAST
CHILLER



NEW!

Now with the eco-friendly R-290 refrigerant!

START WITH A TOUCH

The cabinets are supplied with a graphic touch panel control unit in colour that saves your chilling history with logging.

ADJUSTABLE LEGS
130-180 mm

30%
Lower energy consumption

TECHNICAL DATA

BUILT-IN UNIT

MODEL	POWER SUPPLY	CONNECTED POWER	CHILLING CAPACITY	REFRIGERANT
BRIS-850S3A	230 VAC / 13A	2300 W	36KG	R-452A

REMOTE COOLING UNIT

MODEL	POWER SUPPLY	CONNECTED POWER	CHILLING CAPACITY	COOLING REQUIREMENT (W)	REFRIGERANT
BRIS-850S3C	230 VAC / 10A	1700 W	36KG	2700 / -15°C	R-452A*

*CO2 or other refrigerant can be supplied upon request.

Please note! COOLING REQUIREMENT: A rated requirement. Please note that the evaporator temperature have a need to go lower to reach full capacity, please ask us for consultation.

BRIS 850 BLAST CHILLER CABINET

BLAST CHILLER 45 - 80 KG

REMOTE COOLING UNIT

MODEL	DIM (mm)
BRIS-850S4C	850x765x2160

STANDARD: MADE OF ENTIRELY STAINLESS STEEL / 12 RAIL PAIRS FOR GN1/1 / POWERFUL EVAPORATOR FAN / ADVANCED AIR DISTRIBUTION SYSTEM / GRAPHIC 5.7" TOUCH PANEL CONTROL UNIT IN COLOUR / LOCK / FOOD PROBE

CAPACITY: 45 KG

CAPACITY REFERS TO CHILLING FROM +70°C TO +3°C IN 90 MINUTES

CAPACITY: 125 KG

CAPACITY REFERS TO CHILLING FROM +60°C TO +8°C IN 240 MINUTES

Cabinets with remote cooling unit can be supplied for all refrigerants available on the market, either with a thermal expansion valve or an electronic expansion valve. The includes valve for R-452A (freezer) or R-134a (refrigerator).

EXTRA EQUIPMENT

- LIGHTING
- FOOT PEDAL
- BUILT-IN DATA LOGGING WITH USB PORT
- WHEELS INCLUDING 2 LOCKABLE
- BLAST FREEZER FUNCTION
- HEIGHT=1950 (REMOTE COOLING UNIT)
- CAREL SERIAL CONNECTION MODULE

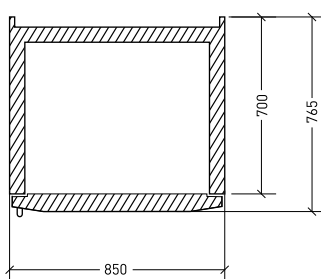

BRIS 850
BLAST
CHILLER

ADJUSTABLE
LEGS
130-180 mm

START WITH A TOUCH

The cabinets are delivered with a graphic touch panel control unit in colour that saves the history for up to one year.

TECHNICAL DATA

REMOTE COOLING UNIT

MODEL	POWER SUPPLY	CONNECTED POWER	CHILLING CAPACITY	COOLING REQUIREMENT (W)	REFRIGERANT
BRIS-850S4C	230 VAC / 10A	1750 W	45 KG	3600 / -15°C	R-452A*

*CO2 or other refrigerant can be supplied upon request.

Please note! COOLING REQUIREMENT: A rated requirement. Please note that the evaporator temperature have a need to go lower to reach full capacity, please ask us for consultation.

STORM 960 BLAST CHILLER CABINET

BLAST CHILLER 50 - 90 KG
BLAST-CHILLER / BLAST-FREEZER ROLL-IN,
FOR RATIONAL ICOMBI/CLASSIC 20-1/1

BUILT-IN UNIT SUITABLE FOR RATIONAL ICOMBI/CLASSIC 20-1/1

MODEL	DIMENSIONS (mm)
STORM-960A-01	960x925x2315
STORM-960FA-01	960x925x2315

REMOTE COOLING UNIT

MODEL	DIMENSIONS (mm)
STORM-960C-01	960x925x2245
STORM-960FC-01	960x925x2245

STANDARD: TOUCH PANEL / SELF-CLOSING DOOR / INSULATED FLOOR / ADAPTED FOR MOBILE OVEN RACKS / ROUNDED INTERIOR CORNERS / ENTIRELY IN STAINLESS STEEL / RIGHT-HINGED DOOR / CONNECTION TO DRAIN

EXTRA EQUIPMENT

STORM+, BUILT-IN DATA LOGGING WITH USB PORT
LIGHTING
LEFT-HINGED DOOR
ADAPTED FOR ELOMA/ELECTROLUX/HOUNÖ
ADAPTED FOR CONVOTHERM
WATER-COOLED CONDENSER
CAREL SERIAL CONNECTION MODULE
* ADDITIONAL EVAPORATOR UNIT FOR STORAGE COOLING (IN-BUILT UNIT)
* ADDITIONAL EVAPORATOR UNIT FOR STORAGE COOLING (REMOTE COOLING UNIT)
CO2 AS REFRIGERANT WITH BUILT-IN UNIT

* Can be supplied with a separate evaporator for storage/storage cooling which reduces energy consumption by approx. 80% when the cabinet runs storage cooling

FUNCTIONS:

The panel comes with 4 different preset programs, in addition to a quick start function and the possibility to change or add custom programs. F models have a blast freezer function.

CAPACITY: 45/50 KG

CAPACITY REFERS TO CHILLING FROM +70°C TO +3°C IN 90 MIN WITH FOOD EVENLY DISTRIBUTED ON A 16 GASTRONORM CONTAINER TROLLEY.

In many cases the capacity is higher than stated. Capacity varies depending on food type and thickness.

ALSO SUITABLE FOR RATIONAL SCC201.

STORM 960
BLAST CHILLER
CABINET
ROLL-IN

NEW!
 Now with the eco-friendly R-290 refrigerant!

SIMPLE TO CONTROL

The STORM touch panel is a graphic panel to easily control and monitor the process.



TECHNICAL DATA

BUILT-IN UNIT

MODEL	POWER SUPPLY	CONNECTED POWER	CHILLING/FREEZING CAPACITY	REFRIGERANT
STORM-960A-01	400 V / 16A	3700 W	45KG/-	R-452A
STORM-960FA-01	400 V / 16A	3750 W	45KG/30KG	- R-452A

REMOTE COOLING UNIT

MODEL	POWER SUPPLY	CONNECTED POWER	CHILLING/FREEZING CAPACITY	COOLING REQUIREMENT (kW)	REFRIGERANT
STORM-960C-01	230 V / 10A	1700 W	50KG	4,0 / -15°C	R-452A*
STORM-960FC-01	230 V / 10A	1750 W	50KG / 50KG	4,0 / -30°C	R-452A*

*CO2 or other refrigerant can be supplied upon request.

Please note! **COOLING REQUIREMENT:** A rated requirement. Please note that the evaporator temperature have a need to go lower to reach full capacity, please ask us for consultation.

BRIS 1200 BLAST CHILLER CABINET

BLAST CHILLER 60 - 100 KG

STORM 1200
BLAST CHILLER
ROOM

REMOTE COOLING UNIT

MODEL	DIMENSIONS (mm)
STORM-1200	1200x950x2160

STANDARD: MADE OF ENTIRELY STAINLESS STEEL / ROLL-IN DESIGN / POWERFUL EVAPORATOR FAN / ADVANCED AIR DISTRIBUTION SYSTEM / GRAPHIC 5.7" TOUCH PANEL CONTROL UNIT IN COLOUR / CABINET DELIVERED WITH HYGIENE TOP COVER

CAPACITY: 60 KG

CAPACITY REFERS TO CHILLING FROM +70°C TO +3°C IN 90 MIN WITH FOOD EVENLY DISTRIBUTED ON A 16 GASTRONORM CONTAINER TROLLEY.

In many cases the capacity is higher than stated. Capacity varies greatly depending on food type and thickness. Rooms are supplied as standard with Hygiene top and valve for R-452A.

EXTRA EQUIPMENT

LIGHTING
STORM+, BUILT-IN DATA LOGGING WITH USB PORT
TUNNEL DESIGN
LEFT-HINGED DOOR
CAREL SERIAL CONNECTION MODULE
*ADDITIONAL EVAPORATOR UNIT FOR STORAGE COOLING

* Can be supplied with a separate evaporator for storage/storage cooling which reduces energy consumption by approx. 80% when the cabinet runs storage cooling

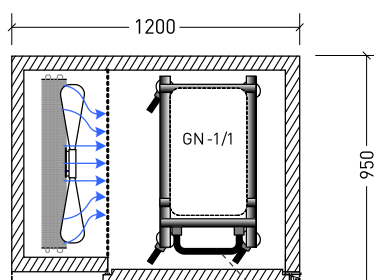

INTERIOR DIMENSIONS

Width: 730 mm
Depth 840 mm

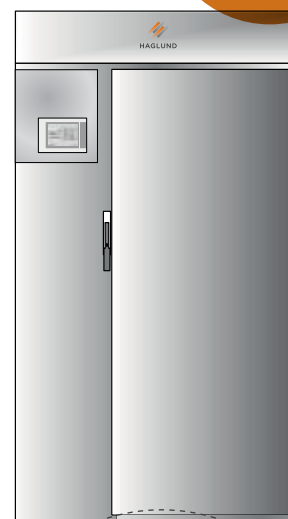

STAINLESS STEEL

The room is made entirely of stainless steel and adapted for a racking trolley. It can be supplied with air control panels adapted for a variety of trolley types upon request.

TECHNICAL DATA

REMOTE COOLING UNIT

MODEL	POWER SUPPLY	CONNECTED POWER	CHILLING CAPACITY	COOLING REQUIREMENT (KW)	REFRIGERANT
STORM-1200	230VAC / 10A	2100 W	60KG	6,0 / -15°C	R-452A*

*CO2 or other refrigerant can be supplied upon request.

Please note! COOLING REQUIREMENT: A rated requirement. Please note that the evaporator temperature have a need to go lower to reach full capacity, please ask us for consultation.

BRIS 1500 BLAST CHILLER CABINET

BLAST CHILLER 80/160 KG



REMOTE COOLING UNIT

MODEL	NUMBER OF TROLLEYS	DIM (mm)
STORM-1500-1	1 GN1/1	1520x1200x2500
STORM-1500-2	2 GN1/1	1520x2320x2500
STORM-1500F-1	1 GN1/1	1520x1200x2500
STORM-1500F-2	2 GN1/1	1520x2320x2500

STANDARD: GRAPHIC 5.7" TOUCH PANEL CONTROL UNIT IN COLOUR / 10 CUSTOM PROGRAMS CAN BE ADDED BY USERS / HISTORY & LOG CAN BE SAVED IN THE PANEL FOR UP TO ONE YEAR, NO EXTERNAL LOGGING FUNCTION OR MANUAL MANAGEMENT OF HISTORY IS NECESSARY (OPTIONAL) / EASY-TO-USE USER INTERFACE / BUILT-IN LANGUAGE MANAGEMENT / ALARM OUTPUT

CAPACITY

STORM-1500-1: 80 KG

STORM-1500-2: 160 KG

CAPACITY REFERS TO CHILLING FROM +70°C TO +3°C IN 90 MIN WITH FOOD EVENLY DISTRIBUTED ON A 16 GASTRONORM CONTAINER TROLLEY.

STORM-1500F-1: 60 KG

STORM-1500F-2: 120 KG

CAPACITY REFERS TO BLAST FREEZER FUNCTION FROM +70 TO -18 DEGREES IN 240 MIN.

In many cases the capacity is higher than stated. Capacity varies greatly depending on food type and thickness.

EXTRA EQUIPMENT

- LIGHTING
- TUNNEL DESIGN
- ADDITIONAL EVAPORATOR UNIT FOR STORAGE COOLING INSTALLATION
- BUILT-IN DATA LOGGING WITH USB PORT
- CAREL PROGRAMMING DISPLAY

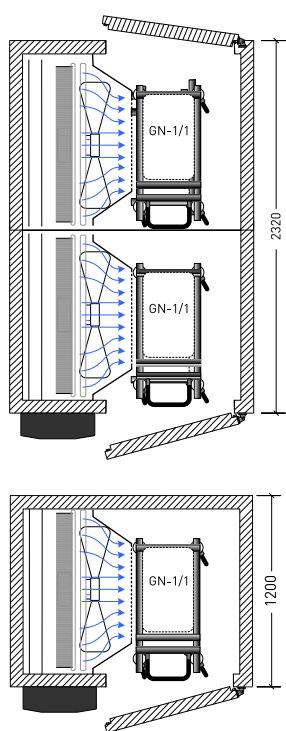

MADE ENTIRELY OF STAINLESS STEEL

The room is made entirely of stainless steel and adapted for 2 racking trolleys GN 1/1 and delivered in modules. It can be adapted with air-control panels for a variety of racking trolleys.

COOLING TECHNOLOGY:

- Equipped with the unique **Direct Cooling** technology.
- A large powerful fan with high capacity.
- Powerful evaporators for efficient chilling and less food product dehydration.
- Each cooler/fan package cools one trolley to ensure even cooling.
- Air flow adapted to gastronorm container trolleys.
- Energy-efficient chilling.

TECHNICAL DATA

REMOTE COOLING UNIT

MODEL	POWER SUPPLY	CONNECTED POWER	CHILLING/FREEZING CAPACITY	COOLING REQUIREMENT (KW)	REFRIGERANT
STORM-1500-1	3x400VAC+N / 10A	2,7 kW	80 KG / -	9,0/-15°C+0,7/-10°C	R-452A*
STORM-1500-2	3x400VAC+N / 10A	5,4 kW	160 KG / -	2x9,0/-15°C+1,0/-10°C	R-452A*
STORM-1500F-1	3x400VAC+N / 10A	2,8 kW	80KG / 60 KG	9,0/-30°C+0,7/-30°C	R-452A*
STORM-1500F-2	3x400VAC+N / 10A	5,6 kW	160 KG / 120 KG	2x9,0/-30°C+1,0/-30°C	R-452A*

*CO2 or other refrigerant can be supplied upon request.

Please note! COOLING REQUIREMENT: A rated requirement please note that the evaporator temperature have a need to go lower to reach full capacity, please ask us for consultation.

BRIS 1800 BLAST CHILLER CABINET

BLAST CHILLER 150/300 KG

REMOTE COOLING UNIT

MODEL	NUMBER OF TROLLEYS	DIM (mm)
STORM-1800-1	1 GN2/1	1800x1360x2600
STORM-1800-2	2 GN2/1	1800x2640x2600
STORM-1800F-1	1 GN2/1	1800x1360x2600
STORM-1800F-2	2 GN2/1	1800x2640x2600

STANDARD: GRAPHIC 5.7" TOUCH PANEL CONTROL UNIT IN COLOUR / 10 CUSTOM PROGRAMS CAN BE ADDED BY USERS / HISTORY & LOG CAN BE SAVED IN THE PANEL FOR UP TO ONE YEAR, NO EXTERNAL LOGGING FUNCTION OR MANUAL MANAGEMENT OF HISTORY IS NECESSARY (OPTIONAL) / EASY-TO-USE USER INTERFACE / BUILT-IN LANGUAGE MANAGEMENT / ALARM OUTPUT

EXTRA EQUIPMENT

LIGHTING
TUNNEL DESIGN
ADDITIONAL EVAPORATOR UNIT FOR STORAGE COOLING
INSTALLATION
BUILT-IN DATA LOGGING WITH USB PORT
CAREL PROGRAMMING DISPLAY

CAPACITY

STORM-1800-1: 150 KG

STORM-1800-2: 300 KG

CAPACITY REFERS TO CHILLING FROM +70°C TO +3°C IN 90 MIN WITH A FOOD THICKNESS OF 50 mm AND WITH FOOD DISTRIBUTED ON A 16 GASTRONORM CONTAINER TROLLEY. MOST DISHES ARE CHILLED MUCH FASTER.

STORM-1800F-1: 120 KG

STORM-1800F-2: 240 KG

CAPACITY REFERS TO BLAST FREEZER FUNCTION FROM +70 TO -18 DEGREES IN 240 MINUTES.

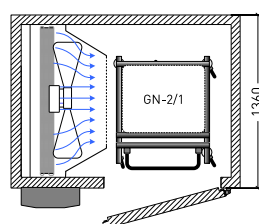
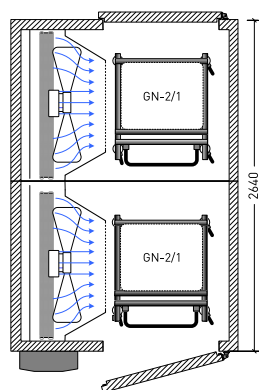

STORM 1800
BLAST
CHILLER
ROOM



MADE ENTIRELY OF STAINLESS STEEL

The room is made entirely of stainless steel and adapted for 2 racking trolleys GN 2/1 and delivered in modules. It can be adapted with air-control panels for a variety of racking trolleys.

COOLING TECHNOLOGY:

Equipped with the unique **Direct Cooling** technology.

A large powerful fan with high capacity.

Powerful evaporators for efficient chilling and less food product dehydration.

Each cooler/fan package cools one trolley to ensure even cooling.

Air flow adapted to gastronorm container trolleys.

Energy-efficient chilling.

TECHNICAL DATA

REMOTE COOLING UNIT

MODEL	POWER SUPPLY	CONNECTED POWER	CHILLING/FREEZING CAPACITY	COOLING REQUIREMENT (KW)	REFRIGERANT
STORM-1800-1	3x400VAC+N/10A	3,6 kW	150KG /-	18,0/-15°C + 0,8/-30°C	R-452A*
STORM-1800-2	3x400VAC+N/16A	7,2 kW	300 KG /-	2x18,0/-15°C + 1,1/-30°C	R-452A*
STORM-1800F-1	3x400VAC+N/10A	3,8 kW	150 KG / 120 KG	18,0/-30°C + 0,8/-30°C	R-452A*
STORM-1800F-2	3x400VAC+N/16A	7,4 kW	300 KG / 240 KG	2x18,0/-15°C + 1,1/-30°C	R-452A*

*CO2 or other refrigerant can be supplied upon request.

PLEASE NOTE! COOLING REQUIREMENT: A rated requirement. The cabinet needs to go down lower in temperature.

Contact us if you have any questions.

MODULAR COLD ROOMS & FREEZER ROOMS

VERTICAL REFRIGERATORS & FREEZER CABINETS

TINA THAWING CABINET

BLAST CHILLER / FREEZER

REFRIGERATED COUNTERS

SERVING COOLING / HEATING

REFRIGERATED WALL DISPLAY

REFRIGERATED DISPLAYS

REFRIGERATED WINE & BEER DISPLAY

HAGLUND INDUSTRI AB
STORA VÄGEN 8, 523 61 GÄLLSTAD, SWEDEN / VÄXEL: +46 (0) 321-299 90
INFO@HAGLUNDINDUSTRI.SE / WWW.HAGLUNDINDUSTRI.SE



**HAGLUND
INDUSTRI**
KYLA I ALLA FORMER