

HAGLUND INDUSTRI

BAKERY

2024



HAGLUND INDUSTRI

KYLA | ALLA FORMER

150 YEARS OF INNOVATION CAN BE SEEN IN THE DETAILS

For five generations, the Haglund family has had its own production at the factory in Sweden. From the early sheet metal workshop to today's high-quality refrigerators, the basic recipe has remained the same: listen to customers, pay attention to details and never stop developing technology and functionality. This tradition is what's built into all our products, giving them a finish and durability that makes us slightly unique. The products are also thoroughly tested, first by us and then by our customers. Try for yourself and notice the difference.

FEEL FREE TO CONTACT US FOR A ESTIMATE

Every restaurant and hospitality establishment has its own needs and specific requirements. We are happy to help you find a solution that suits your needs the best. Call or email us and tell us what you need and we will give you a proposal and ON REQUEST.

EMAIL US: SALES@HAGLUNDINDUSTRI.SE

OR CALL: +46 (0) 321-29 990

3 BAKERY

4 BRIS 600 BAKERY CABINET
REFRIGERATORS & FREEZERS

5 BRIS 600 PROOFING CABINET

6 REFRIGERATED BAKERY COUNTER

7 FREEZER BAKERY COUNTER



**HAGLUND
INDUSTRI**
KYLA I ALLA FORMER

BAKERY

BRIS 600 BAKERY REFRIGERATOR/FREEZER CABINET / BRIS 600 PROOFING CABINET / REFRIGERATED BAKERY COUNTER / FREEZER BAKERY COUNTER

OUR BAKERY RANGE IS DESIGNED TO MEET THE DEMANDING REQUIREMENTS AND TEMPERATURE SENSITIVITY OF THE BAKERY INDUSTRY. THROUGH TECHNOLOGICAL DEVELOPMENTS, WE HAVE SIMPLIFIED CONTROLS WITH THE BRIS 600 SYSTEM WITHOUT COMPROMISING ON QUALITY. WE HAVE ALSO LAUNCHED TWO PRACTICAL REFRIGERATION AND FREEZER COUNTERS SPECIFICALLY FOR BAKERIES.



BRIS 600 PROOFING CABINET



MBF BAKERY COUNTER FREEZER

MBK REFRIGERATED BAKERY COUNTER

BRIS 600 BAKERY CABINET

SIMPLIFIED CONTROL OF THE BRIS 600 PROOFING CABINET
 Proof your bread when it suits you.
 The BRIS cabinet keeps an eye on the proofing.



NEW



DRY COOLING AS STANDARD

BRIS 600 BAKERY CABINET

REFRIGERATORS/FREEZERS

BUILT-IN UNIT

MODEL	TYPE	DIM (mm)
BRIS-600BKA	BAKERY REFRIGERATOR	600x865x2160
BRIS-600BFA	BAKERY FREEZER	600x865x2160**

REMOTE COOLING UNIT

MODEL	TYPE	DIM (mm)
BRIS-600BKC	BAKERY REFRIGERATOR	600x865x2160
BRIS-600BFC	BAKERY FREEZER	600x865x2160

STANDARD: MADE OF ENTIRELY STAINLESS STEEL / LOCK / REMOVABLE EVAPORATOR TRAY IN STAINLESS STEEL / LOW-ENERGY FAN / HYGIENE TOP COVER (REMOTE COOLING UNIT) / PROTECTIVE COATED EVAPORATOR

Remote Cooling Unit can be supplied for all refrigerants available on the market, either with a thermal expansion valve or an electronic expansion valve. The includes valve for R-452A (freezer) or R-134a (refrigerator).

EXTRA EQUIPMENT

ELECTRONIC EXPANSION VALVE
WHEELS INCLUDING 2 LOCKABLE
ELECTRONIC HYGROSTAT FOR HUMIDITY CONTROL

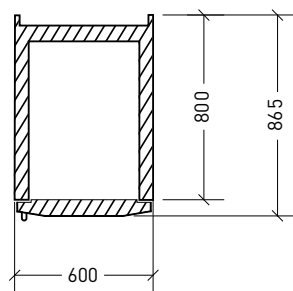

BRIS 600
BAKERY
CABINET



DRY COOLING AS STANDARD

BRIS 600 bakery cabinets are always equipped with a dry cooling function as standard.

STÄLLBARA
BEN
130 - 180 mm

Supplied with 27 pairs of removable guides for baking trays with dimensions 450x600 mm (can also be supplied for trays with dimensions 400x600 mm).

TECHNICAL DATA

BUILT-IN UNIT

MODEL	POWER REQUIREMENT	CONNECTED POWER	REFRIGERANT
BRIS-600BKA	230V/10A	360W	R-290
BRIS-600BFA	230V/10A	640W	R-290

REMOTE COOLING UNIT

MODEL	POWER SUPPLY	CONNECTED POWER	COOLING REQUIREMENT (W)	REFRIGERANT
BRIS-600BKC	230V/10A	145W	250/-8°C	R-452A/R-134a*
BRIS-600BFC	230V/10A	630W	300/-28°C	R-452A*

*CO2 or other refrigerant can be supplied upon request.

BRIS 600 PROOFING CABINET

PROOFING CABINET

BUILT-IN UNIT

MODEL	TYPE	DIM (mm)
BRIS-600BKJA	BAKERY REFRIGERATOR/PROOFING CABINET	600x865x2200
BRIS-600BFJA	BAKERY FREEZER/PROOFING CABINET	600x865x2200

REMOTE COOLING UNIT

MODEL	TYPE	DIM (mm)
BRIS-600BKJC	BAKERY REFRIGERATOR/PROOFING CABINET	600x865x2160
BRIS-600BFJC	BAKERY FREEZER/PROOFING CABINET	600x865x2160

STANDARD: MADE OF ENTIRELY STAINLESS STEEL / LOCK / LOW-ENERGY FAN / HYGIENE TOP COVER (REMOTE COOLING UNIT) / PROTECTIVE COATED EVAPORATOR

EXTRA EQUIPMENT

ADAPTED FOR GN1/1

ADAPTER FOR BAKING TRAYS 400x600 mm

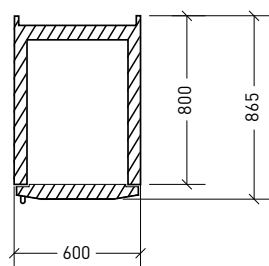

BRIS 600
REFRIGERATOR/
PROOFING



**REFRIGERATOR/
PROOFING**

Proof your bread when it suits you. The BRIS cabinet keeps an eye on the proofing for you.

**ADJUSTABLE
LEGS**
130-180 mm

Delivered with 4 guide racks for bakery trays with dimensions 450x600 mm, 14 trays in total.

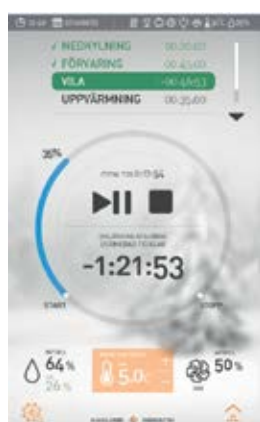
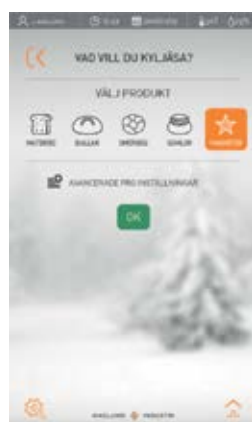
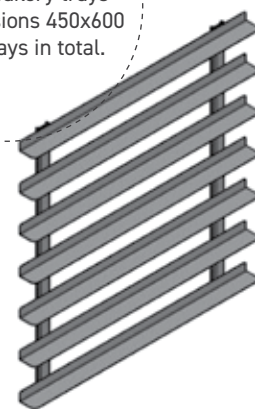

NEW

TECHNICAL DATA

BUILT-IN UNIT

MODEL	POWER SUPPLY	CONNECTED POWER	REFRIGERANT
BRIS-600BKJA	230V/10A	1500 W	R-290
BRIS-600BFJA	230V/10A	1500 W	R-290

REMOTE COOLING UNIT

MODEL	POWER SUPPLY	CONNECTED POWER	COOLING REQUIREMENT (W)	REFRIGERANT
BRIS-600BKJC	230V/10A	1500 W	900/-8°C	R-452A/R-134a*
BRIS-600BFJC	230V/10A	1500 W	300/-28°C	R-452A*

*CO2 or other refrigerant can be supplied upon request.

REFRIGERATED BAKERY COUNTER

REFRIGERATED BAKERY COUNTER

DEPTH 700 mm

MODEL	DOORS	DIM (mm)
MBK-150A	2	1500x700x900
MBK-210A	3	2100x700x900
MBK-260A	4	2600x700x900

MBK
REFRIGERATED
BAKERY
COUNTER

STANDARD: INTERIOR AND EXTERIOR IN STAINLESS STEEL / AUTOMATIC DEFROST / INTEGRATED COOLING UNIT / FAN COOLER / ELECTRIC CONDENSATE EVAPORATOR / FOR TRAYS 450x600 mm

NOTE! GASTRONORM
CONTAINERS NOT INCLUDED

EXTRA EQUIPMENT

ENVIRONMENTALLY FRIENDLY REFRIGERANT R-290
STAINLESS RAIL INTERIOR
ELECTRONIC HYGROSTAT (NOT WITH 4 DOORS)

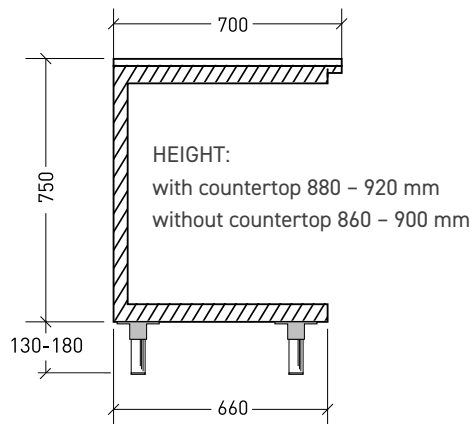

TECHNICAL DATA

BUILT-IN UNIT

MODEL	POWER SUPPLY	CONNECTED POWER	REFRIGERANT
MBK-150A	230V / 10A	450 W	R-290
MBK-210A	230V / 10A	550 W	R-290
MBK-260A	230V / 10A	650 W	R-290

*CO2 or other refrigerant can be supplied upon request.

BAKERY COUNTER FREEZER

BAKERY COUNTER FREEZER

BUILT-IN UNIT

MODEL	DOORS	DIM (mm)
MBF-110A	1	1100x700x900
MBF-150A	2	1550x700x900

STANDARD: INTERIOR AND EXTERIOR IN STAINLESS STEEL / AUTOMATIC DEFROST / INTEGRATED COOLING UNIT / FAN COOLER / ELECTRIC CONDENSATE EVAPORATOR / GUIDES FOR 450x600 TRAYS

NOTE! GASTRONORM CONTAINERS NOT INCLUDED

EXTRA EQUIPMENT

ENVIRONMENTALLY FRIENDLY REFRIGERANT R-290
STAINLESS RAIL INTERIOR

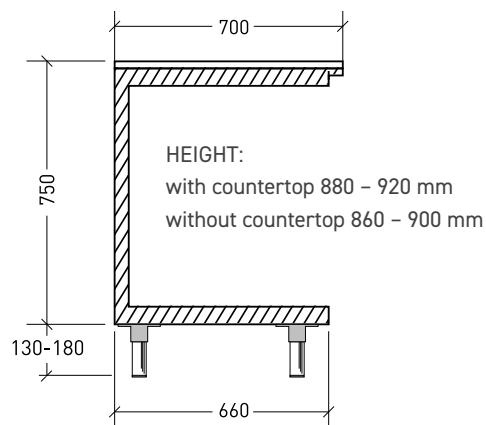

MBF
BAKERY
COUNTER
FREEZER

TECHNICAL DATA

BUILT-IN UNIT

MODEL	POWER SUPPLY	CONNECTED POWER	REFRIGERANT
MBF-110A	230V/10A	450W	R-290
MBF-150A	230V/10A	550W	R-290

*CO2 or other refrigerant can be supplied upon request.



MODULAR COLD ROOMS & FREEZER ROOMS
VERTICAL REFRIGERATORS & FREEZER CABINETS
TINA THAWING CABINET
BLAST CHILLER / FREEZER
REFRIGERATED COUNTERS
SERVING COOLING / HEATING
REFRIGERATED WALL DISPLAY
REFRIGERATED DISPLAYS
REFRIGERATED WINE & BEER DISPLAY

HAGLUND INDUSTRI AB
STORA VÄGEN 8, 523 61 GÄLLSTAD, SWEDEN / VÄXEL: +46 (0) 321-299 90
INFO@HAGLUNDINDUSTRI.SE / WWW.HAGLUNDINDUSTRI.SE



**HAGLUND
INDUSTRI**
KYLA I ALLA FORMER